

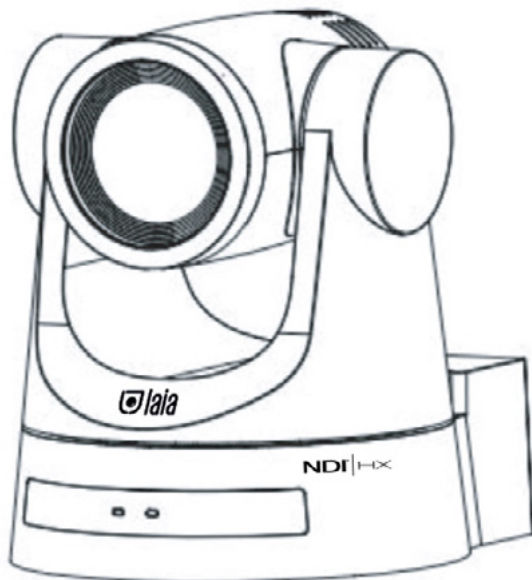

User Manual
Broadcaster 30X

P/N: BRC-130 ST



Index

1. Know your product.	1
2. What's in the box	1
3. Product Features	1
4. Interface	1
5. How to use the device	2
6. Network connection	7
6.1 Connection methods	7
6.2 Camera web interface	8
7. Configuration of the camera	8
7.1 Audio Configure	9
7.2 Video Configure	9
7.2.1 Video Encode	9
7.2.2 Stream Publish	9
7.2.3 Multicast/Unicast:	10
7.2.4 Video parameters:	10
7.2.5 Video OSD	12
7.2.6 OSD Font Size	12
7.2.7 Video Out	12
7.3 Network Configure	12
7.3.1 Network port:	12
7.3.2 Ethernet	13
7.3.3 DNS	13
7.3.4 GB28181:	13
7.3.5 SRT:	13
7.3.6 NDI	14
7.3.7 RTSP:	14
7.4 System Configure	14
7.4.1 System Attribute	14
7.4.2 USB Disk Store	15
7.4.3 USB Disk Store Settings	15
7.4.4 USB Disk Record	15
7.4.5 System Time	15
7.4.6 System User	15
7.4.7 Update	16
7.4.8 Default	16
7.4.9 Reboot	16
7.4.10 Log out	16
8. Serial port communication control	17

8.1 VISCA protocol command list	17
8.1.1 VISCA Protocol list	17
8.1.2 Device control command	17
8.1.3 Enquiry Command	25
8.1.4 Pelco-D Protocol command list	28
8.1.5 Pelco-P Protocol command list	29
9. Specifications	30
9.1 Camera Lens Parameter	30
9.2 Interface Parameter	31
10. Mounting options	33
10.1 Wall mounting	33
10.2 Ceilling Mount	33
11. Troubleshooting & tips	34
11.1 Camera maintenance	34
11.2 Not recommended uses	34
11.3 Problem solving	34
12. Interface	35

1. Know your product.



2. What's in the box



3. Product Features

The Broadcaster 30X camera offers perfect functions, superior performance and rich interfaces. The features include advanced ISP processing algorithms to provide vivid images with a strong sense of depth, high resolution, and fantastic color rendition. It supports H.264/H.265 encoding which makes motion video fluent and clear even under less than ideal bandwidth conditions.

- Full HD image: 1/2.8-inch 2.07 million pixel high-quality image sensor, the maximum resolution can reach 1920x1080, and the output frame rate can reach 60 frames/second.
- Optical Zoom Lens: 30X optical
- Leading Auto Focus Technology: Fast, accurate and stable auto focusing technology.
- Low Noise and High SNR: Super high SNR image is achieved with low noise CMOS. Advanced 2D/3D noise reduction technology further reduces the noise while ensuring high image clarity.
- Multiple Video Output Methods: HDMI, SDI, CVBS, LAN for video output. Both video and audio can be output from HDMI, SDI, LAN at the same time. The transmission distance of SDI 1080p60 is up to 100 meters.
- Multiple Audio/Video Compression Standards: Support H.265/H.264 video compression, support AAC, MP3, G.711A audio compression; support up to 1920x1080 resolution 60 frames/second compression.
- Audio Input Interface: Support AAC, MP3, G.711A audio encoding, AAC, MP3 support 16000, 32000, 44100, 48000 sampling rate.

- Automatic gyroscope: Built in Gravity Sensor
- Multiple Network Protocol: Support ONVIF, GB/T28181, RTSP, RTMP, VISCA OVER IP, IP VISCA, RTMPS, SRT protocols; Support RTMP push mode, easy to be connected to streaming server (Wowza, FMS); Support RTP multicast mode;
- NDI Support: NDI® | HX version2
- Control Jack: RS422 input (compatible with RS485), RS232 input/output, RS232 (cascading connection)
- Low Power Sleep Mode: Support low power sleep/awake mode, and the power consumption is less than 400mW.
- Multiple Control Protocol: Support VISCA, PELCO-D, PELCO-P protocols; Support automatic identification protocols.
- Multiple Presets: Up to 255 presets (10 presets via remote control).

4. Interface

External interface diagram

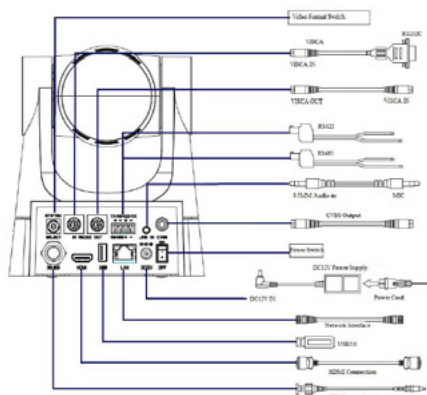

RS-232 diagram

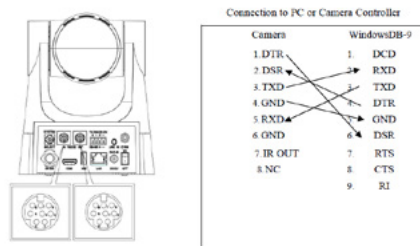

Rotary switch

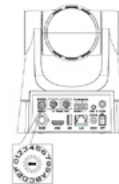

Rotary Dip Switch 0 F Video Formats

- 0 Video Format: 1080P60
- 1 Video Format: 1080P50
- 2 Video Format: 1080I60
- 3 Video Format: 1080I50
- 4 Video Format: 720P60
- 5 Video Format: 720P50
- 6 Video Format: 1080P30
- 7 Video Format: 1080P25
- 8 Video Format: 720P30
- 9 Video Format: 720P25
- A: -----
- B: -----
- C: -----
- D: CVBS output 576i
- E: CVBS output 480i
- F: video format to be set on the menu

Note: After turning the dial to change the video format, it will take effect after turning off and restarting the power.

5. How to use the device

Video output

After turning on the camera, you will have an initial setup and the light on the receiver will flash. The camera will do a short pan and tilt tour to return to the home position, or if preset 0 is set, the camera will return to the preset 0 position.

Network output:

Connect this product to your computer via a network cable, open the browser, enter the IP address of the camera (default 192.168.5.163) in the address bar, go to the login page and enter a username and password (by default "admin").

SDI, HDMI output:

Connect the monitor with the corresponding video output interface.

Remote control



- Standby key

After a long press of 3', the camera will enter standby mode. Long press 3' again, the camera will self-diagnose again and return to the HOME position.

Note: If the power-on mode is on and preset 0 is set, and there is no operation in 12', it will automatically point to the specified preset position.

- Camera direction selection

Select the direction of the camera you want to control.

Numeric key: Set or run presets 0-9.

Key, *, # : Use of the key combination.

Focus control key: Enter auto focus mode. Manual Focus: The focus mode of the camera is manual.

Change the focus mode of the camera to manual focus by pressing [focus +] or [focus -] to adjust it.

- Zoom control key

Zoom + = zoom in / zoom - = zoom out.

- Set or Clear Preset key:

• Preset: Preset key + number key 0-9. Clear Preset: Clear preset key + numeric key 0-9.

- Pan/Tilt control keys : The arrows indicate the direction of the camera once you press it. "HOME" key returns the camera to the middle position or enter the following menu.

- BLC control key : On/Off black light.

- Menu setting : Open or close OSD menu.

- Infrared remote control configuration: By pressing the key combination indicated below, we assign the remote control to the address indicated in Camera Select



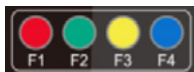

- [*] + [#] + [F1]: Camera Address N° 1
- [*] + [#] + [F2]: Camera Address N° 2
- [*] + [#] + [F3]: Camera Address N° 3
- [*] + [#] + [F4]: Camera Address N° 4

Note: In practice this means that with a single remote control we can manage 4 cameras simultaneously

Functions when combining keys

- [#] + [#] + [#]: Clear all presets
- [#] + [#] + [6]: Restore factory defaults
- [#] + [#] + [3]: Menu set to Chinese
- [#] + [#] + [4]: Menu set to English
- [#] + [#] + [9]: Flip switch
- [*] + [#] + Auto: Enter aging mode
- [#] + [*] + Auto: Exit aging mode
- [*] + [#] + Manual: Restore the default user name, password, and IP address
- [#] + [#] + [0]: Switch the video format to 1080P60
- [#] + [#] + [1]: Switch the video format to 1080P50
- [#] + [#] + [2]: Switch the video format to 1080I60
- [#] + [#] + [3]: Switch the video format to 1080I50
- [#] + [#] + [4]: Switch the video format to 720P60
- [#] + [#] + [5]: Switch the video format to 720P50
- [#] + [#] + [6]: Switch the video format to 1080P30
- [#] + [#] + [7]: Switch the video format to 1080P25
- [#] + [#] + [8]: Switch the video format to 720P30
- [#] + [#] + [9]: Switch the video format to 720P25

Using the remote control

After initialization is complete, you can receive and execute the commands from the remote control. When you press the button on the remote, the indicator light flashes, and when you release the button, the indicator light stops flashing. Users can control pan, tilt and zoom, as well as adjust and run presets using the infrared remote control.

Camera selection



Select here the camera you want to control.

Pan/Tilt



The arrows indicate the direction of movement of the camera.

Press and hold the up/down /left/right key and he will start moving, from slow to fast, until he reaches the end point. It will stop working as soon as you release the key.

Zoom control



Zoom in or out by pressing Zoom+ /Zoom-.

Hold down the key and the camera will continue to zoom in or out and stop as soon as you release the key.

Focus control



Focus near or far by pressing Focus+ /Focus- (only valid in manual mode)

Select auto or manual to activate the function.

Focus will stop as soon as you release the key.

Presets, operation and delete

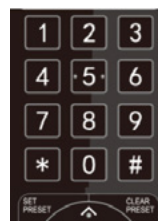

- Preset: To set a preset, select "SET PRESET" and then press number key 0-9. Note: the remote control has 10 presets.
 - Preset: Directly press 0-9 keys to run a preset.
- Note:** Action in vain if there is no previous preselection.
- Clear preset: To clear a preset, first press "CLEAR PRESET" key, and then press number key 0-9 to clear it.
- Note:** Press the "#" key three times in succession to cancel all the presets.

Menu settings

In normal operating mode, press the "MENU" key to display the menu, using the scroll arrow to point or highlight selected items.

This is the general outline of the camera menus and submenus.

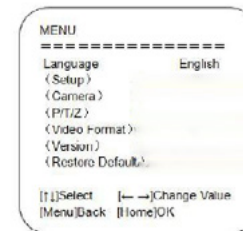
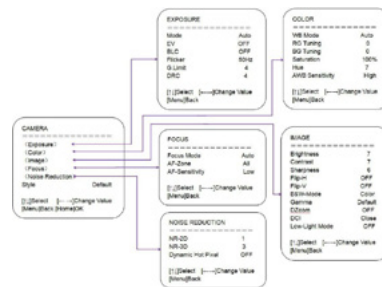
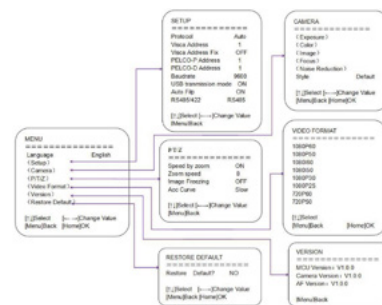

Setup

Move the pointer to (Setup) in the main menu, click "HOME", and enter the (Setup) as shown below

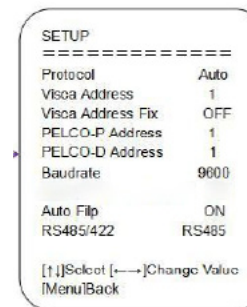

- **Protocol:** Values: Auto, VISCA, Pelco-D, Pelco-P
 - **Visca Address :** Values 1-7 Default: 1
 - **Visca Address Fix:** Values On/Off Default: OFF
 - **Pelco-P Address:** 1-255 Default: 1
 - **Pelco-D Address :** 1-255 Default 1
 - **Baud rate:** 2400/4800/9600/38400/115200 Default: 9600
 - **Auto Flip:** Values ON/ OFF Default ON:
 - **RS485 /422:** Values RS485/RS422
- Use the arrows to scroll through the main menu and select the value you want to edit or set. Select "HOME" to go back.

Initial menu

Use the arrows to scroll through the main menu and select the value you want to edit or set. Select "HOME" to go back.

Camera settings

Move the pointer to the (Camera) in the main menu, click the "HOME" key and enter the (Camera) as shown below:

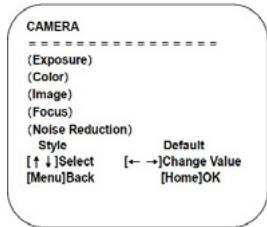

Use the arrows to scroll through the main menu and select the value you want to edit or set. Select "HOME" to go back.

Exposure

Move the pointer to the (Exposure) in the main menu, click the "HOME" key and enter the (Exposure set) as shown below:

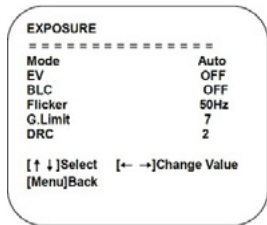

- **Mode** : Auto, Manual, SAE, AAE, Bright
- **EV** : On/Off (only in auto mode)
- **EV level**: -7~7 (only in auto mode when EV is on)
- **BLC**: On/Off (only in auto mode)
- **Flicker**: Off/50Hz/60Hz (only in Auto, AAE or Bright Mode)
- **G. Limit**: 0-15(only in Auto, AAE or Bright Mode)
- **DRC**: Close,1~8.
- **Iris**: Close, F11.0,F9.6,F8.0,F6.8,F5.6,F4.8,F4.0,F3.4,F2.8,F2.4,F2.0,F1.8 (only in Manual or AAE Mode)
- **Shutter**: 1/25, 1/30, 1/50, 1/60, 1/90, 1/100, 1/120, 1/200, 1/250, 1/350, 1/500, 1/1000, 1/2000, 1/3000, 1/4000, 1/6000, 1/10000 (only in Manual or SAE Mode)
- **Gain**: 0-15(only in Manual or SAE Mode)
- **Bright**: 0~20 (only in Bright Mode)

Color

Move the pointer to (Color) in the main menu, click "START" and enter the (Color adjustment) as follows:

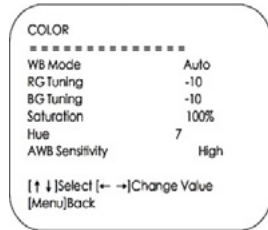

- **WB Mode**: Auto, Manual, OnePush, VAR
- **RG Tuning**: -10~10 (only available in Auto WB mode)
- **BG Tuning**: -10~10 (only available in Auto WB mode)
- **Saturation**: 0~127
- **Hue**: 0~8
- **AWB sensitivity**: High/Middle/Low (only available in Auto WB mode)
- **RG (Red Gain)**: 0~100(only available in manual mode)
- **BG (Blue Gain)**: 0~100(only available in manual mode)
- **Color temperature**: 2400K~7100K (only in VAR Mode)

Image

Move the pointer to (IMAGE) in the main menu, click "START" and enter the (IMAGE) as follows:

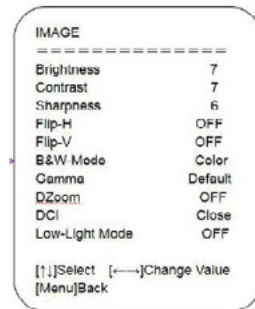

- **Brightness**: 0~100
- **Contrast**: 0~100
- **Sharpness**: 0~15
- **Flip-H**: OFF, ON
- **Flip-V**: OFF, ON
- **B&W-Mode**: Color, B&W
- **Gamma**: Default 0.45, 0.50, 0.55, 0.63
- **DZoom**: Digital Zoom Options: On/Off
- **DCI**: Close, Open
- **Low Light Mode**: On/Off

Focus

Move the pointer to (Focus) in the main menu, click

"HOME" and enter the (Focus) as follows:

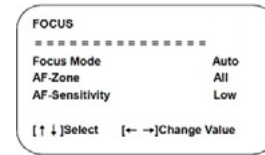

- **Focus Mode**: Auto, Manual, OnePush
- **AF Zone**: All/Top/Center/Bottom
- **AF Sensitivity**: High, Middle, Low

Noise reduction

Move the pointer to (Noise reduction) in the main menu, click "START" and enter (Noise reduction) as follows:

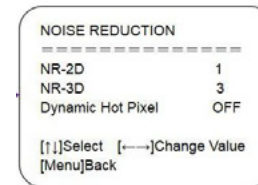

- **NR-2D**: Values: Auto, Off, 1-8
- **NR-3D**: Values: Auto, Off, 1-8
- **Dynamic Hot Pixel**: Off, On

PTZ

Move the pointer to (PTZ) in the main menu, click "HOME" and enter the (PTZ) as follows:

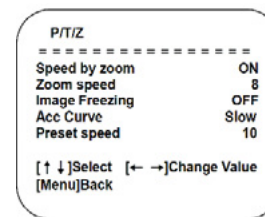

- **Speed by zoom**: Values: On, Off
- **Zoom speed**: Adjust the zoom speed for the remote control. Values 1~8
- **ImageFreezing**: On/Off
- **Acc Curve**: Fast/Slow
- **Preset speed**: 1-10

Video format

Move the pointer to (Video format) in the main menu, click "START" and enter the (Video format) as follows:

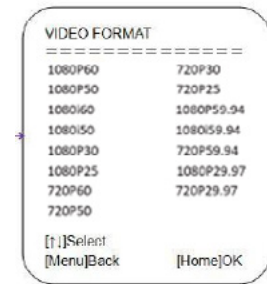

Version

Move the pointer to (Version) in the main menu, click "START" and enter the (Version) as follows:

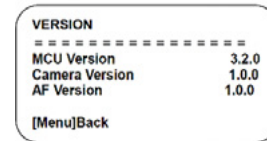

- **MCU Version**: Displays the MCU software version.
- **Camera Version**: Displays the software version of the camera.

AF Version: Displays the focus software version of the camera.

Restore defaults

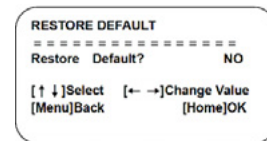

- Move the pointer to (Restore defaults) in the main menu, click "START" and enter the (Restore defaults) as follows:
- **Restore Defaults**: Yes/No (After restoring defaults, language, color and video format will not be restored.)
- **Note**: If the previous remote control address is not 1, but other than 2,3,4, the corresponding camera address will be reset to 1 when all parameters are reset. User should change the remote address to 1 (press No.1 according to the camera to get normal operation).

6. Network connection

6.1 Connection methods

- Direct connection: Direct connections via "Crossover" network cable.
- Internet connection mode: Connection via a router or switch using a network cable between the camera and the router or switch.

Note: Please do not place the power and network cables where they can be easily touched to avoid poor video quality due to unstable signal transmission due to poor contact of the cables.

The computer must have the network segment to which the IP address of the camera belongs. The device will not be accessible if it does not have the segment. For example, if the default IP address of the camera is 192.168.5.163, segment 5 needs to be added on the computer.

The specific steps are:

First of all, open the properties window of the computer's local area connection and select "Internet Protocol version 4 (TCP/IPv4)", as shown in the image on the left. Double-click or click the "Internet Protocol version 4 (TCP/IPv4)" Property to access the Internet Protocol version 4 (TCP/ IPv4) properties window, select "Advanced" to access advanced settings of TCP/IP and add the IP and subnet mask in the IP explorer.

Select "OK" to finish adding the IP segment. User can add the corresponding network segment according to the revised IP address of the camera.

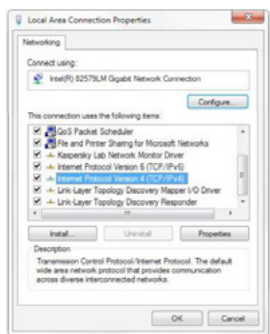

Note: The IP address to be added cannot be the same as that of other computers or devices. It is necessary to verify the existence of this IP address before adding it. Select "Start" and select "Run" to enter cmd as shown in the following image to check if the network segment has been added successfully.

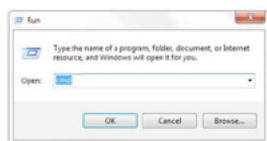

After the self-test of the camera is finished, the user can also check the network connection by following the steps mentioned above. If the IP is the default, open the DOS command window, enter 192.168.5.163 and press "ENTER".

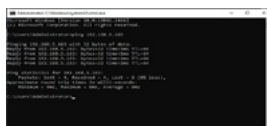

It will show message as below: which means network connection is normal.

6.2 Camera web interface

- Web login

After assigning an IP address to the camera, you can access the Web Interface by typing the camera's IP address in a web browser.



You can log in to this interface as an administrator or as a user. If you are doing this as an administrator, type "admin" in the username and password fields. If doing so as a user, enter "user1" or "user2" in the username and password fields. From the Web Interface, you can control the camera using the arrows on the left. You can also adjust many of the camera's settings through this IP interface.

Note:

- Login as administrator

Default username and password: **admin**

You have full access to configure all the parameters of the camera.



- Login as a user

Default username and password: **"user1"** or **"user2"**.

You can control the parameters of the PTZ camera and the tracking of the camera. You do not have access to the settings menu.



- Supported browsers: Google Chrome, Internet Explorer, Microsoft Edge, Firefox, etc.

Preview

After logging into the management interface, enter the video preview interface. On the preview screen, users can control PTZ, zoom, focus, video capture, sound, focus, full screen and set preset position, run, delete and other operations.

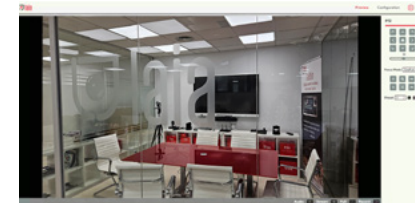

Audio Enable or Disable Audio

Stream Enable the Camera Stream as defined in the Video Configure menu

Full Show the camera image in full screen

Record Enable camera recording. An external USB drive needs to be connected to the USB2.0 port of the camera. How to configure recording will be explained in more detail in the description of the recording menu.

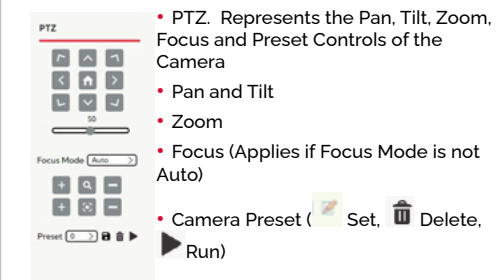

7. Configuration of the camera

Click "Configuration" to enter the device parameter setting page.

There are the following options: Audio Configure, Video Configure, Network Configure and System Configure

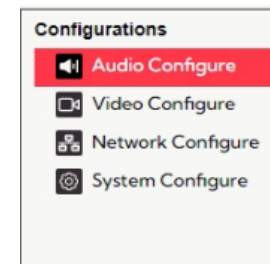

Detailed description see the following table:

Menu	Explanation
Audio Configure	Including audio compressing format, sampling frequency, sampling precision, compressing code rate settings etc.
Video Configure	Including video encoding, video parameters, character-overlapping, character size, video output setting etc.
Network Configure	Including basic parameters, Ethernet, DNS, wireless network setting, GB28181 etc.
System Configure	Including equipment property, system time, user management, version update, Reset, Reboot device settings etc.

7.1 Audio Configure

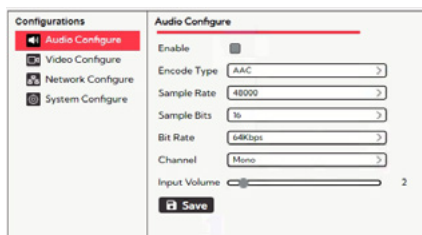

- **Enable:** Choose whether or not to activate audio.
 - **Encode Type:** Set the audio compression format and manually reset the device after change (MP3,PCM,AAC optional by default)
 - **Sample Rate:** Set the sampling rate and manually reset the device after change (MP3, AAC default 16000, 32000, 44100, 48000 optional, G.711A default is 8000)
 - **Sample Bits:** Set the sampling precision (default 16bits)
 - **Bit Rate:** Set the audio compression rate (default 64 Kbps, 32, 48, 96,128 Kbps optional)
 - **Channel :** Set the channel type (default mono, optional stereo)
 - **Input volume:** Adjust the input volume (default 2.1-10 optional)
- Note:** Click "Save" and this message appears will appear. Reboot the camera for it to take effect.

7.2 Video Configure

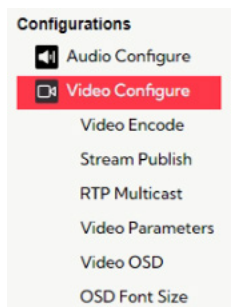

7.2.1 Video Encode

You can configure the video stream parameters of the camera



- **Compressed format:** Set video compression format, save to take effect (Main/Sub stream, default: H.264,H.265 optional)
- **Profile:** Profile mode setting (default HP, BP, MP optional)
- **Image size:** Adjust the video image resolution, save to take effect (main stream default 1920*1080 optional 1280*720, 640*480; sub stream default 320*180,optional 640*360, 320*240,640*480, 1280*720,1920*1080 optional)
- **Rate control:** Set the rate control mode, save to take effect (main/sub stream defaults to fix rate (CBR), variable bit rate (VBR) is for option)
- **Image quality:** Image quality can only be changed when rate control is VBR, (default main stream is best, default secondary is better, optional values Best, Better, Good, Bad, Worse, Worst)
- **Bit Rate (Kb/s):** Set the video bit rate (main stream default 8192 Kb/s,64- 12288Kb/s optional; sub stream default 512 Kb/s,64-10240 Kb/s optional)
- **Frame Rate (F/S):** Adjust the video frame rate (default primary/sub stream 30 and 25F/S, primary stream 5-30F/S optional, sub stream 5-30F/S optional)
- **I Frame Interval:** Set the keyframe interval (Primary/Secondary stream default 90/75F, Primary/Secondary stream 1-150F optional. Secondary stream 1-150F

optional)

- **I Frame Min QP:** Adjust the keyframe interval minimum QP (20 default, 10-51 optional)
- **Stream Name:** When streaming via rtsp or rtmp, the user can modify the stream name. Main Stream(live/av0), sub stream(live/av1)

Note: Click "Save" button to pop up the message, then the settings will take effect

7.2.2 Stream Publish

You can configure the stream publish parameters of the camera when you want to broadcast live video on the internet



- **Enable:** To turn on/off the main/sub stream.
- **Protocol Type:** Main/Sub stream protocol Values: RTMP, RTSP and SRT
- **Host Address:** IP addresses of the server (default 192.168.5.11)
- **Host Port:** Host port number (default 1935,0-65535 optional)
- **Stream Name:** Choose a different stream name (live/av0,live/av1 optional)
- **Username :** Set the username. It does not apply in protocol type SRT
- **Password:** Set the password. It does not apply in protocol type SRT
- **Password for stream encryption:** only applies to protocol type SRT
- **Crypto key length in bytes:** only applies to protocol type SRT Values 0,16,24,32

Note: Click "Save" button to display, then the settings will take effect

7.2.3 Multicast/Unicast:

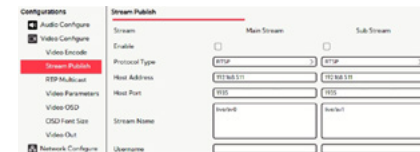

Enable: Main/Sub Stream: On/Off.

- **Protocol Type:** RTP or TS.
- **Address:** Default 224.1.2.3. It can be edited.
- **Port:** Primary default is 4000, secondary 4002, and primary/secondary is optional from 0 to 65535.
- **Access Method:** The address appears after setting. Ex: rtp://224.1.2.3:4000, udp://@224.1.2.3:4000, tcp://@224.1.2.3:4002

Note: Click "Save" button to display, then the settings will take effect.

7.2.4 Video parameters:

1. Focus

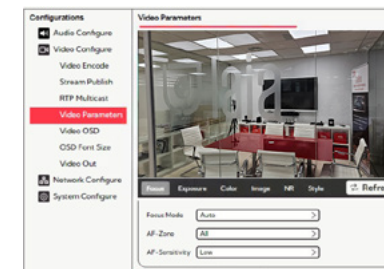

- **Focus Mode:** Set the focus mode (default auto, optional manual, one-push)
- **AF-Zone:** Set the autofocus zone (default All, optional Top, Center, Bottom)
- **AF-Sensitivity:** Set the focus sensitivity (default is low, high and middle optional)

2. Exposure

- **Exposure:** Exposure mode, exposure compensation, backlight compensation, anti-flicker, gain limit, dynamic range, shutter, aperture, brightness, gain can be adjusted

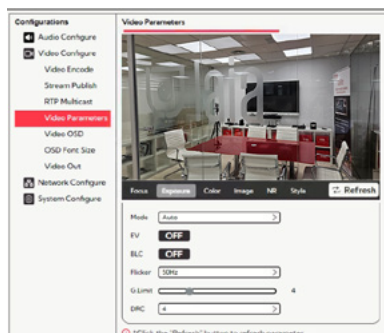

- **Mode** : Auto, Manual, SAE, AAE, Bright
- **EV** : On/Off (only in auto mode)
- **EV level**: -7~7 (only in auto mode when EV is on)
- **BLC**: On/Off (only in auto mode)
- **Flicker**: Off/50Hz/60Hz (only in Auto, AAE or Bright Mode)
- **G. Limit**: 0~15(only in Auto, AAE or Bright Mode)
- **DRC**: Close,1~8.
- **Iris**: Close, F11.0,F9.6,F8.0,F6.8,F5.6,F4.8,F4.0,F3.4,F2.8,F2.4,F2.0,F1.8 (only in Manual or AAE Mode)
- **Shutter**: 1/25, 1/30, 1/50, 1/60, 1/90, 1/100, 1/120, 1/200, 1/250, 1/350, 1/500,1/1000, 1/2000, 1/3000, 1/4000, 1/6000, 1/10000, 1/20000 (only in Manual or SAE Mode)
- **Gain**: 0~15(only in Manual or SAE Mode)
- **Bright**: 0~20 (only in Bright Mode)

3. Color

Color: White balance, saturation, hue, white balance sensitivity, red fine tune, blue fine tune, red gain, blue gain can be adjusted.

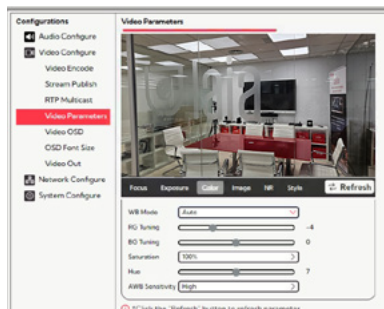

- **WB Mode**: Auto, Manual, OnePush, VAR
- **RG Tuning**: -10~10 (only available in Auto WB mode)
- **BG Tuning**: -10~10 (only available in Auto WB mode)
- **Saturation**: 0~127

- **Hue**: 0~8
- **AWB Sensitivity**: High/Middle/Low (only available in Auto WB mode)
- **RG (Red Gain)**: 0~100(only available in manual mode)
- **BG (Blue Gain)**: 0~100(only available in manual mode)
- **Color temperature**: 2400K-7100K (only in VAR Mode)

4. Image

Image: You can adjust the brightness, contrast, sharpness, gamma curve, dynamic contrast, black and white mode, horizontal flip, vertical flip, electronic zoom, ultra-low illumination.

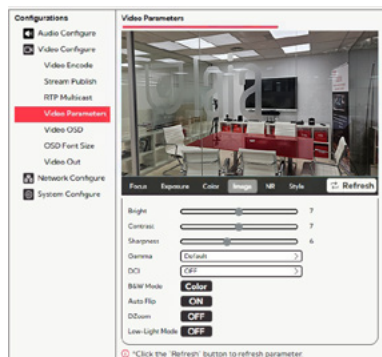

- **Bright**: 0~100
- **Contrast**: 0~100
- **Sharpness**: 0~15
- **Gamma**: Default 0.45, 0.50, 0.55, 0.63
- **B&W-Mode**: Color, B&W
- **Auto Flip**: ON, Off
- **DZoom**: Digital Zoom Options: On/Off
- **Low Light Mode**: On/Off

5. NR

Noise Reduction: 2D noise reduction, 3D noise reduction and dynamic dead pixel correction available.

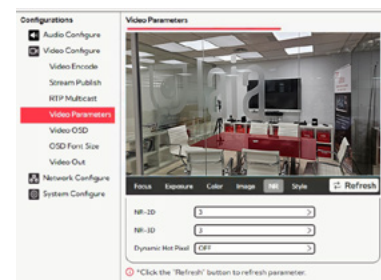

- **NR-2D**: Adjust the level of 2D noise reduction (default 3, 1~8 and optional off).
- **NR-3D**: Adjust the 3D noise reduction level (default 3, 1~8 and off optional)
- **Dynamic Hot Pixel**:

6. Style

- **Style**: Image selection (standard, brightness, clarity etc.. can be configured)

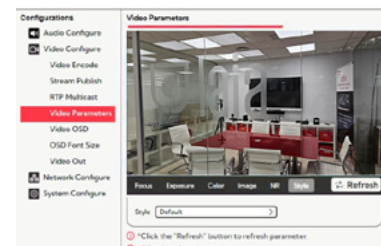

- **Style**: Values: Default, Normal, Clarity, Bright, Soft
- **Note**: Refresh the page after changing the parameters for them to take effect.

7.2.5 Video OSD

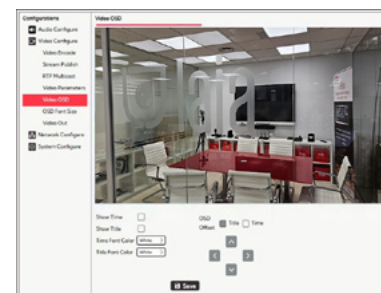

Character Overlay:

- **Show time** : Yes/No

- **Show Title**: Yes/No
 - **Time Font Color**: Default white, black, yellow, red and blue optional)
 - **Title Font Color**: Default white, black, yellow, red and blue optional)
 - **OSD Offset**: Set the location where the time and title will be displayed. Press "up, down, left, right" button to move character location.
 - **Title**: Set the title on the device property (default CAMERA1)
 - **Time**: Set the time based on the system time (default 1970/01/01 05:36:00)
- Note**: Press "Save" button, the "Save the parameters successfully" window will pop up, which means the settings will take effect

7.2.6 OSD Font Size

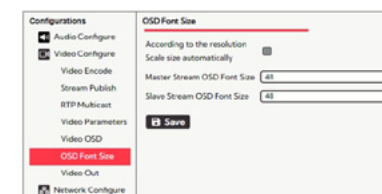

Character size:

- According to the resolution Scale size automatically: Enable/ Disable
 - **Master Stream OSD Font Size**: Adjust the display character size, the device will automatically reboot after switching (default 48, 28-200 optional)
 - **Slave Stream OSD Font Size**: Adjust the screen character size, the device will automatically reboot after switching (default 48, 28-200 optional)
- Note**: Click the "Save" button to pop up the ""Save the parameters successfully" window.

7.2.7 Video Out

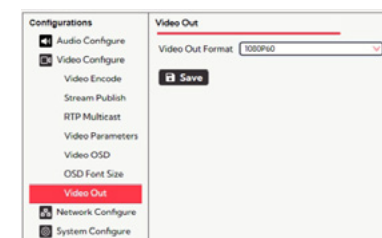

Adjustment of video output format

- **Video Out format**: Values: 1080P60, 1080P50, 1080i60, 1080i50, 1080P30, 1080P25, 720P60, 720P50Default: 1080P60

Note: Click the "Save" button to pop up the ""Save the parameters successfully" window.

parameters successfully" window.

7.3 Network Configure



7.3.2 Ethernet

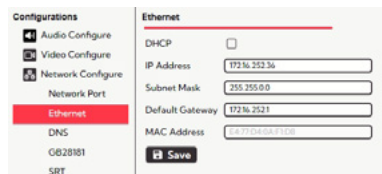

- **DHCP:** Activate or deactivate obtain IP automatically. After saving, please reboot the device to take effect (default: Off)
- **IP Address:** Set the IP address (default 192.168.5.163)
- **Subnet Mask:** Set the Subnet Mask
- **Default Gateway:** Set the Default Gateway
- **MAC Address:** It shows the MAC Address of the camera (Not configurable)

Note: Click "Save" button, it will be valid when "Save successfully" appears.

Once saved, please reboot the device to take effect

7.3.3 DNS

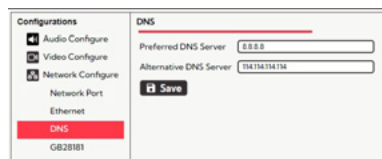

- **Preferred DNS Server:** Set the preferred DNS server. (Default 0.0.0.0)
- **Alternative DNS Server:** Set the alternate DNS server. (Default 0.0.0.0)

7.3.4 GB28181:

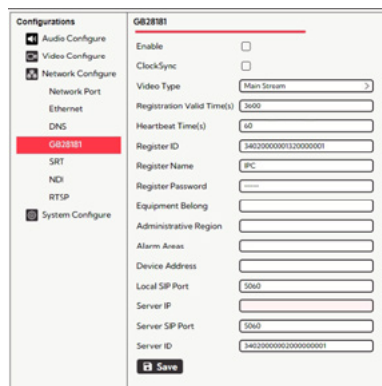

- **Port Data:** Set the data port, the device will automatically reboot after changing it (default 3000.0-65535 optional)
 - **Port Web:** Set the web port, the device will automatically reboot after changing (default is 80, 0-65535 is optional)
 - **Port Onvif:** Set the Onvif port, the device will automatically reboot after switching (default 2000, 0-65535 optional)
 - **Port Soap:** Set the soap port (default 1936, 0-65535 optional)
 - **Port RTMP:** Set the RTMP port (default 1935, 0-65535 optional)
 - **Port Rtsp:** Set the RTSP port, the device will automatically reboot after switching (default 554.0-65535 optional)
 - **Port Visca:** Set the Visca port, the device will automatically reboot after changing it (default 3001.0-65535 optional)
 - **Port Https:** Set the http port, the device will automatically reboot after changing (default 443, 0-65535 optional)
- Note:** Click "Save" button, it will be valid when it shows "Save successfully".

- **Enable:** Set whether to activate GB28181.
- **ClockSync:** Enables/Disables time synchronization.
- **VideoType:** Set the stream type (default Main Stream, optional Sub Stream)
- **Registration Valid Time** (in seconds): 3600, range 5-65535.
- **Heartbeat time** (in seconds): 60, range 1-65535.
- **Register ID:** 34020000001320000001
- **Register Name:** Default: IPC.
- **Register Password:** Default: 12345678.
- **Equipment Belong:** Users can add their own.
- **Administrative Region:** Users can add their own.
- **Alarm Areas:** Users can add their zone.
- **Device Address:** Users can add their own.
- **Local SIP Port:** Default: 5060 Range 0-65535.
- **Server IP:** IP address of the server GB28181.
- **Server SIP Port:** Default: 5060 Range 0-65535
- **Server ID:** Default: 34020000002000000001.

7.3.5 SRT:

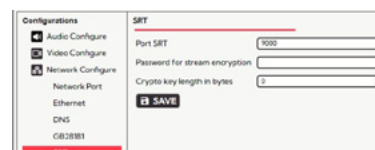

- **Port SRT:** Set the SRT port (default 9000, 0-65535 optional).
- **Password for the stream encryption:** Set the SRT password.
- **Crypto key length in bytes:** Set the length of the SRT password (default 0, 16, 24, 32 optional).

Note: Click the "SAVE" button and this message appears

7.3.6 NDI

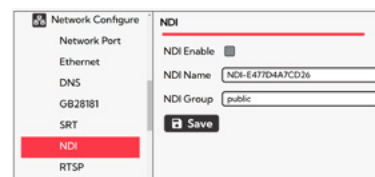

- **NDI Enable:** Enable or disable NDI feature
- **NDI Name:** Defines the camera name for NDI applications
- **NDI Group:** Defines the NDI group to which the camera belongs

7.3.7 RTSP:

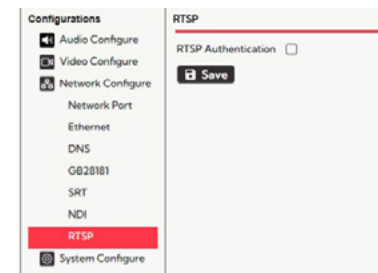

- **RTSP Authentication:** Enable the RTSP authentication, default off, on optional.
- Note:** Changing the RTSP authentication parameters will take effect after the device is rebooted.

7.4 System Configure



7.4.1 System Attribute

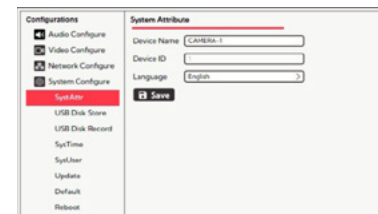

- **Device Name:** Set the device name (Camera 1 by default, user can add their own)

- **Device ID:** Set the device ID (default 1, read only)
- **Language:** Set the system language (default Simplified Chinese/ English) It is necessary to log in again after modifying and saving the settings.

7.4.2 USB Disk Store

You can record the video from the camera

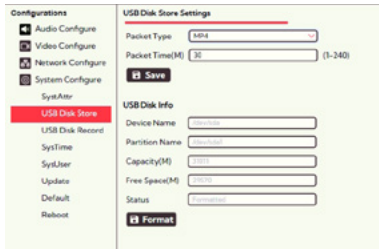

Connect USB Flash Drive to the USB2.0 port on the camera and configure the recording parameters

7.4.3 USB Disk Store Settings

Packet Type: MP4 or TS

Packet Time(M): 1-240

USB Disk Info. It shows the USB Disk Information connected to USB 2.0 Port

Press Format if you need to format the USB Disk

7.4.4 USB Disk Record

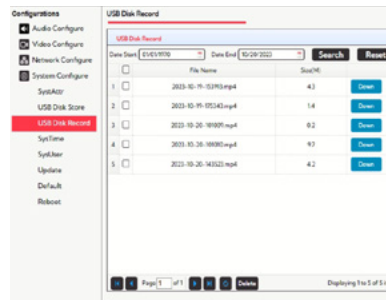

You can view the recorded files on the USB disk. Press "Down", save the file on your PC and now you can play the video

7.4.5 System Time



- **Date Format:** Set the date format (YYYY-MM-DD, MM-DD-YYYY, DD-MM-YYYY)
- **Date separator:** Set the date separator (default '/' '-' '-')
- **Zone:** Set the time zone (default UTC+0 8:00, other time zones optional)
- **Hour Type:** Set the time types (default 24 hours, optional 12 hours)
- **NTP Enable:** Enable/disable NTP.
- **Update Interval:** Set the automatic update interval of the NTP server. Valid after setting synchronization with NTP server (default one day, 2 / 10 days optional)
- **Host Url:** Set the NTP server address or domain name (default time.nits.gov) Valid after setting NTP server synchronization.
- **Host port:** Set NTP server port (default 123) Valid after setting NTP server synchronization from the NTP server.
- **Time Settings**
 - **Time Settings:** Values: Synchronize with computer time, Synchroniza with NTP server, Set manually
 - **Computer Time:** Only appears if Time Setting is

manually or computer time

7.4.6 System User

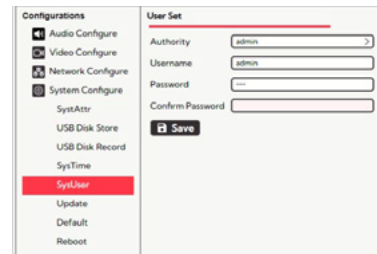

- **Authority:** Set the type of user (the default administrator, user 1, user2 optional)
- **Username:** Set the user name (select user admin, default admin. Select common user1, default user1, to select common user 2, default user2, user can modify their own)
- **Password:** Set a password (select user admin, default admin. Select a common user1, default user1, to select a common user2 default user2, user can modify their own)
- **Confirm Password:** Confirm whether the entered passwords are the same or not.

7.4.7 Update

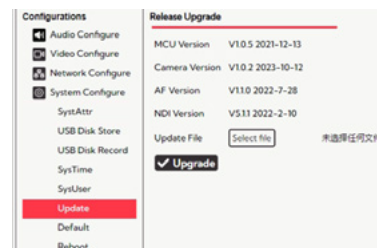

- **MCU Version:** Displays the MCU software version.
- **Camera Version:** Displays the software version of the camera.
- **AF Version:** Displays the focus software version of the camera
- **Update file:** Click "Select File" in the pop-up window and select the update file, then press the "Upgrade" button. The update dialog box will pop up. After the update is done, the device will reboot automatically.
- **Note:** Please make sure the device power and network can work during the update, if not, the update will fail. After the version upgrade is finished, you will need to restore factory defaults: a) restore factory defaults via web setting, b) restore factory defaults via menu, c) restore factory defaults factory defaults with the hot key '#6 on the remote control. Choose one of the three

methods above, in which the "a method" IP account and password are also restored to default.

7.4.8 Default

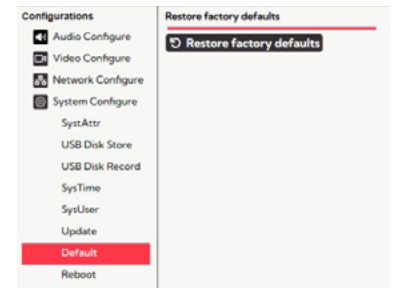

Select "Restore factory defaults button and choose "yes" or "no" in the pop- up window.



The device will automatically reboot and restore factory settings.

7.4.9 Reboot

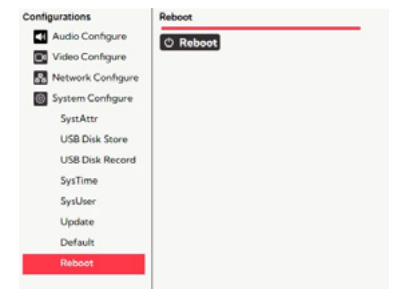

Press "Reboot" button and choose "yes" or "no" in the pop-up window.

The device will reboot automatically

7.4.10 Log out

Click [Logout] and select "yes" or "no" in the pop-up window. If you choose "Yes", you will exit the current page and return to the user login interface again.

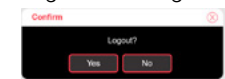

8. Serial port communication control

In normal working state, you can control the camera via RS232/RS485 cable (VISCA IN). The RS232 parameters are as follows:

Baud rate: 2400/4800/9600/115200/second. Start bit: 1 bit.

Data bit: 8 bit.

Stop bit: 1 bit.

Check bit: None.

After power on, the camera will make a brief turn and return to the center position.

The zoom lens is moved to the farthest position and then backed out, after the self-test is complete.

8.1 VISCA protocol command list

8.1.1 VISCA Protocol list

Ack/Completion Message		
	Command Package	Remark
ACK	z0 41 FF	Returned when the command is accepted.
Completion	z0 51 FF	Returned when the command has been executed.
Error Message		
	Command Package	Remark
Syntax error	z0 60 02 FF	Returned when the command format is different or when a command with illegal command parameters is accepted.
Command buffer full	z0 60 03 FF	Indicates that two sockets are already being used(executing two commands) and the command could not be accepted when received.
Command canceled	z0 6y 04 FF (y: socket No.)	Returned when a command which is being executed in a socket specified by the cancel command is canceled. The completion message for the command is not returned.
No socket	z0 6y 05 FF (y: socket No.)	Returned when no command is executed in a socket specified by the cancel command, or when an invalid socket number is specified
Command not executable	z0 6y 41 FF(y: Execution command Socket No. Inquiry command: 0)	Returned when a command cannot be executed due to current conditions.For example, when commands controlling the focus manually are received during auto focus.

8.1.2 Device control command

Command	Function	Command package	Remark
Address Set	Broadcast	88 30 0p FF	p:Address setting

IF_Clear	Broadcast	88 01 00 01 FF	I/F Clear
CAM_Power	On	8x01 04 00 02 FF	Power ON/OFF
	Off	8x01 04 00 03 FF	
CAM_Zoom	Stop	8x01 04 07 00 FF	p=0(low)-7(high) pqrs=Zoom position
	Tele(Standard)	8x01 04 07 02 FF	
	Wide(Standard)	8x01 04 07 03 FF	
	Tele(Variable)	8x01 04 07 2p FF	
	Wide(Variable)	8x01 04 07 3p FF	
	Direct	8x01 04 47 0p 0q Or 0s FF	
	CAM_Focus	Stop	
Far(Standard)		8x 01 04 08 02 FF	
Near(Standard)		8x 01 04 08 03 FF	
Far (Variable)		8x 01 04 08 2p FF	
Near (Variable)		8x 01 04 08 3p FF	
Direct		8x 01 04 48 0p 0q Or 0s FF	
Auto focus		8x 01 04 38 02 FF	
Manual focus		8x 01 04 38 03 FF	
One push mode		8x 01 04 38 04 FF	
One push trigger		8x 01 04 18 01 FF	One push trigger
CAM_Zoom Focus	Direct	8x 01 04 47 0p 0q Or 0s 0t Ou 0v 0w FF	pqrs: Zoom Position tuvw: Focus Position
CAM_AF Sensitivity	High	8x 01 04 58 01 FF	Focus sensitivity setting
	Normal	8x 01 04 58 02 FF	
	Low	8x 01 04 58 03 FF	

CAM_AF Zone	Top	8x 01 04 AA 00 FF	Focus Region Setting
	Center	8x 01 04 AA 01 FF	
	Bottom	8x 01 04 AA 02 FF	
	All	8x 01 04 AA 03 FF	

Command	Function	Command package	Remark
CAM_WB	2400K	8x 01 04 35 0C FF	
	2500K	8x 01 04 35 0D FF	
	2600K	8x 01 04 35 0E FF	
	2700K	8x 01 04 35 0F FF	
	2800K	8x 01 04 35 10 FF	
	2900K	8x 01 04 35 11 FF	
	3000K	8x 01 04 35 01 FF	
	3100K	8x 01 04 35 12 FF	
	3200K	8x 01 04 35 13 FF	
	3300K	8x 01 04 35 14 FF	
	3400K	8x 01 04 35 15 FF	
	3500K	8x 01 04 35 07 FF	
	3600K	8x 01 04 35 16 FF	
	3700K	8x 01 04 35 17 FF	
	3800K	8x 01 04 35 18 FF	
	3900K	8x 01 04 35 19 FF	
	4000K	8x 01 04 35 02 FF	
	4100K	8x 01 04 35 1A FF	
	4200K	8x 01 04 35 1B FF	
	4300K	8x 01 04 35 1C FF	
	4400K	8x 01 04 35 1D FF	
	4500K	8x 01 04 35 08 FF	
	4600K	8x 01 04 35 1E FF	
	4700K	8x 01 04 35 1F FF	
	4800K	8x 01 04 35 21 FF	
	4900K	8x 01 04 35 22 FF	
	5000K	8x 01 04 35 04 FF	
	5100K	8x 01 04 35 23 FF	
	5200K	8x 01 04 35 24 FF	
	5300K	8x 01 04 35 25 FF	

	5400K	8x 01 04 35 26 FF	
	5500K	8x 01 04 35 09 FF	
	5600K	8x 01 04 35 27 FF	
	5700K	8x 01 04 35 28 FF	
	5800K	8x 01 04 35 29 FF	
	5900K	8x 01 04 35 2A FF	
	6000K	8x 01 04 35 0A FF	
	6100K	8x 01 04 35 2B FF	
	6200K	8x 01 04 35 2C FF	
	6300K	8x 01 04 35 2D FF	
	6400K	8x 01 04 35 2E FF	
	6500K	8x 01 04 35 06 FF	
	6600K	8x 01 04 35 2F FF	
	6700K	8x 01 04 35 30 FF	
	6800K	8x 01 04 35 31 FF	
	6900K	8x 01 04 35 32 FF	
	7000K	8x 01 04 35 0B FF	
	7100K	8x 01 04 35 33 FF	
	One Push mode	8x 01 04 35 03 FF	
	One Push Trigger	8x 01 04 10 05 FF	
Manual	8x 01 04 35 05 FF		

Command	Function	Command package	Remark
CAM_AWB Sensitivity	Low	8x 01 04 A9 00 FF	WB Sensitivity Setting
	Normal	8x 01 04 A9 01 FF	
	High	8x 01 04 A9 02 FF	
CAM_RGain	Reset	8x 01 04 03 00 FF	Manual Control of R Gain
	Up	8x 01 04 03 02 FF	
	Down	8x 01 04 03 03 FF	
	Direct	8x 01 04 43 00 00 0p 0q FF	pq: R Gain

CAM_Bgain	Reset	8x 01 04 04 00 FF	Manual Control of B Gain
	Up	8x 01 04 04 02 FF	
	Down	8x 01 04 04 03 FF	
	Direct	8x 01 04 44 00 00 Op 0q FF	pq: B Gain
CAM_AE	Full Auto	8x 01 04 39 00 FF	Automatic Exposure mode
	Manual	8x 01 04 39 03 FF	Manual Control mode
	Shutter Priority	8x 01 04 39 0A FF	Shutter Priority Automatic Exposure mode
	Iris Priority	8x 01 04 39 0B FF	Iris Priority Automatic Exposure mode
	Bright	8x 01 04 39 0D FF	Bright mode
CAM Shutter	Reset	8x 01 04 0A 00 FF	Shutter Setting
	Up	8x 01 04 0A 02 FF	
	Down	8x 01 04 0A 03 FF	
	Direct	8x 01 04 4A 00 00 Op 0q FF	pq: Shutter Position
CAM_Iris	Reset	8x 01 04 0B 00 FF	Iris Setting
	Up	8x 01 04 0B 02 FF	
	Down	8x 01 04 0B 03 FF	
	Direct	8x 01 04 4B 00 00 Op 0q FF	pq: Iris Position
CAM_Gain Limit	Reset	8x 01 04 0C 00 FF	Gain Limit Setting
	Up	8x 01 04 0C 02 FF	
	Down	8x 01 04 0C 03 FF	
	Gain Limit	8x 01 04 2C 0p FF	p: Gain Positon
CAM_Bright	Reset	8x 01 04 0C 00 FF	Bright Setting
	Up	8x 01 04 0C 02 FF	
	Down	8x 01 04 0C 03 FF	
	Direct	8x 01 04 4D 00 00 Op 0q FF	pq: Bright Positon

CAM_Expcom	On	8x 01 04 3E 02 FF	Exposure Compensation ON/OFF
	Off	8x 01 04 3E 03 FF	
	Reset	8x 01 04 0E 00 FF	Exposure Compensation Amount Setting
	Up	8x 01 04 0E 02 FF	
	Down	8x 01 04 0E 03 FF	
Direct	8x 01 04 4E 00 00 Op 0q FF	pq: ExpComp Position	
CAM_Back Light	On	8x 01 04 33 02 FF	Back Light Compensation
	Off	8x 01 04 33 03 FF	
CAM_WDRS trength	Reset	8x 01 04 21 00 FF	WDR Level Setting
	Up	8x 01 04 21 02 FF	
	Down	8x 01 04 21 03 FF	
	Direct	8x 01 04 51 00 00 00 0p FF	p: WDR Level Positon
CAM_NR	2D	8x 01 04 53 0p FF	P=0-8 0:OFF
	3D	8x 01 04 54 0p FF	
CAM_Gamma		8x 01 04 5B 0p FF	p = 0 - 4 0:Default 1:0.45 2:0.50 3:0.55 4: 0.63

Command	Function	Command package	Remark
CAM_Low- Light Mode	On	8x 01 04 2D 01 FF	Low-Light Mode Setting
	Off	8x 01 04 2D 00 FF	
CAM_Gain		8x 01 04 4C 00 00 Op 0q FF	pq: 0-15
CAM PresetSpeed		8x 01 01 0p FF	p: 1-10
CAM_Flicker	Off	8x 01 04 23 00 FF	Off
	50Hz	8x 01 04 23 01 FF	50Hz
	60Hz	8x 01 04 23 02 FF	60Hz

CAM_ Aperture	Reset	8x 01 04 02 00 FF	Aperture Control
	Up	8x 01 04 02 02 FF	pq: Aperture Gain
	Down	8x 01 04 02 03 FF	
	Direct	8x 01 04 42 00 00 0p 0q FF	
CAM_Picture effect	B&W-Mode	8x 01 04 63 04 FF	
CAM_Me- mory	Reset	8x 01 04 3F 00 pq FF	pq: Memory Number(=0 to 254) Corresponds to 0 to 9 on the Remote Commander
	Set	8x 01 04 3F 01 pq FF	
	Recall	8x 01 04 3F 02 pq FF	
CAM_LR_ Reverse	On	8x 01 04 61 02 FF	Image Flip Horizontal ON/OFF
	Off	8x 01 04 61 03 FF	
CAM_Pictu- reFlip	On	8x 01 04 66 02 FF	Image Flip Vertical ON/ OFF
	Off	8x 01 04 66 03 FF	
CAM_Color- Saturation	Direct	8x 01 04 49 00 00 00 0p FF	P:CAM_ColorSaturation
CAM_ IDWrite		8x 01 04 22 0p 0q 0r 0s FF	pqrs: Camera ID (=0000 to FFFF)
SYS_Menu	On	8x 01 04 06 06 02 FF	Turn on/off the menu screen
	Off	8x 01 04 06 06 03 FF	
IR_Receive	On	8x 01 06 08 02 FF	IR(remote commander) receive On/ Off
	Off	8x 01 06 08 03 FF	
CAM_Setting Reset	Reset	8x 01 04 A0 10 FF	Reset Factory Setting
CAM_ Brightness	Direct	8x 01 04 A1 00 00 0p 0q FF	pq: Brightness Position
CAM_ Contrast	Direct	8x 01 04 A2 00 00 0p 0q FF	pq: Contrast Position
CAM_Flip	Off	8x 01 04 A4 00 FF	Single Command For Video Flip
	Flip-H	8x 01 04 A4 01 FF	
	Flip-V	8x 01 04 A4 02 FF	
	Flip-HV	8x 01 04 A4 03 FF	

CAM_ VideoSystem	Set Camera video system	8x 01 06 35 00 0p FF	P: Video format 0:1080P60; 1:1080P50 4:720P60; 5:720P50 6:1080P30; 7:1080P25 A:1080P59.94; C:720P59.94; D:1080P29.97; OX:19:4KP30; OX1A:4KP25
Pan_tiltDrive	Up	8x 01 06 01 VV WW 03 01 FF	VV: Pan speed 0x01 (low speed) to 0x18 (high speed) WW: Tilt speed 0x01 (low speed) to 0x14 (high speed)
	Down	8x 01 06 01 VV WW 03 02 FF	
	Left	8x 01 06 01 VV WW 01 03 FF	
	Right	8x 01 06 01 VV WW 02 03 FF	YYYY: Pan Position ZZZZ: Tilt Position
	Upleft	8x 01 06 01 VV WW 01 01 FF	
	Upright	8x 01 06 01 VV WW 02 01 FF	
	Downleft	8x 01 06 01 VV WW 01 02 FF	

Command	Function	Command package	Remark
	Down right	8x 01 06 01 VV WW 02 02 FF	
	Stop	8x 01 06 01 VV WW 03 03 FF	
	Absolute Position	8x 01 06 02 VV WW 0Y 0Y 0Y 0Y 0Z 0Z 0Z 0Z FF	
	Relative Position	8x 01 06 03 VV WW 0Y 0Y 0Y 0Y 0Z 0Z 0Z 0Z FF	
	Home	8x 01 06 04 FF	
	Reset	8x 01 06 05 FF	
Pan- tiltLimitSet	Set Clear	8x 01 06 07 00 0W 0Y 0Y 0Y 0Y 0Z 0Z 0Z 0Z FF 8x 01 06 07 01 0W 07 0F 0F 0F 07 0F 0F 0F FF	W:1 UpRight 0:DownLeft YYYY: Pan Limit Position(TBD) ZZZZ: Tilt Limit Position(TBD)

8.1.3 Enquiry Command

Command	Command package	Return Package	Remark
CAM_ PowerIn q	8x 09 04 00 FF	y0 50 02 FF	On
		y0 50 03 FF	Off(Standby)
CAM_ ZoomPo slnq	8x 09 04 47 FF	y0 50 0p 0q Or 0s FF	pqrs: Zoom Position
CAM_ FocusA FModelnq	8x 09 04 38 FF	y0 50 02 FF	Auto Focus
		y0 50 03 FF	Manual Focus
		y0 50 04 FF	One Push mode
CAM_ FocusP oslnq	8x 09 04 48 FF	y0 50 0p 0q Or 0s FF	pqrs: Focus Position
CAM_ AFSensitivityInq	8x 09 04 58 FF	y0 50 01 FF	High
		y0 50 02 FF	Normal
		y0 50 03 FF	Low
CAM_ AFZone Inq	8x 09 04 AA FF	y0 50 00 FF	Top
		y0 50 01 FF	Center
		y0 50 02 FF	Bottom
		y0 50 03 FF	All
CAM_ WBMod elnq	8x 09 04 35 FF	y0 50 pq FF	Pq=WBMode
CAM_ AWBSe nsitivityInq	8x 09 04 A9 FF	y0 50 00 FF	High
		y0 50 01 FF	Normal
		y0 50 02 FF	Low
CAM_ RGainIn q	8x 09 04 43 FF	y0 50 00 00 0p 0q FF	pq: R Gain
/	8x 09 04 44 FF	y0 50 00 00 0p 0q FF	pq: B Gain
CAM_ AEMod elnq	8x 09 04 39 FF	y0 50 00 FF	Full Auto
		y0 50 03 FF	Manual
		y0 50 0A FF	Shutter priority
		y0 50 0B FF	Iris priority
		y0 50 0D FF	Bright

CAM_Shutter PosInq	8x09044AFF	y0 5000000p0q FF	pq: Shutter Position
CAM_ IrisPosl nq	8x09044BFF	y0 5000000p0q FF	pq: Iris Position
CAM_Gain LimitInq	8x 09 04 2C FF	y0 50 0p FF	p: Gain Positon
CAM_ BrightPosilnq	8x 09 04 4D FF	y0 5000000p0q FF	pq: Bright Position
CAM_ExpCo mpModelnq	8x 09 04 3E FF	y0 50 02 FF	On
		y0 50 03 FF	Off

Command	Command pac- kage	Return Package	Remark
CAM_ExpCo mpPosInq	8x 09 04 4E FF	y0 50 00 00 0p 0q FF	pq: ExpComp Position
CAM_ Backligh tModelnq	8x 09 04 33 FF	y0 50 02 FF	On
		y0 50 03 FF	Off
CAM_ WDRStr engthInq	8x 09 04 51 FF	y0 50 00 00 00 0p FF	p: WDR Strength
CAM_ NRLeve l(2D) Inq	8x 09 04 53 FF	y0 50 0p FF	P: 2DNRLevel
CAM_ NRLeve l(3D) Inq	8x 09 04 54 FF	y0 50 0p FF	P:3D NRLevel
CAM_ FlickerM odelnq	8x 09 04 55 FF	y0 50 0p FF	p: Flicker Settings(0: OFF, 1: 50Hz, 2:60Hz)
CAM_ Apertur elnq	8x 09 04 42 FF	y0 50 00 00 0p 0q FF	pq: Aperture Gain
CAM_ PictureE ffectModelnq	8x 09 04 63 FF	y0 50 00 FF	Off
		y0 50 04 FF	B&W
CAM_ Memory	8x 09 04 3F FF	y0 50 0p FF	p: Memory number last operated
SYS_ MenuMo delnq	8x 09 06 06 FF	y0 50 02 FF	On
		y0 50 03 FF	Off
CAM_LR_ Rev erselnq	8x 09 04 61 FF	y0 50 02 FF	On
		y0 50 03 FF	Off

CAM_ PictureF lipInq	8x 09 04 66 FF	y0 5002FF	On
		y0 5003FF	Off
CAM_ ColorSa turationInq	8x090449FF	y0 50 00 00 Op FF	p: Color Gain setting Oh (60%) to Eh (130%)
CAM_IDInq	8x 09 04 22 FF	y0 50 Op FF	p: Camera ID
IR_ReceiveInq	8x 09 06 08 FF	y0 50 02 FF	On
		y0 50 03 FF	Off
CAM_ Brightne sslInq	8x 09 04 A1 FF	y0 50 00 00 Op Oq FF	pq: Brightness Position
CAM_ Contrast Inq	8x 09 04 A2 FF	y0 50 00 00 Op Oq FF	pq: Contrast Position
CAM_FlipInq	8x 09 04 A4 FF	y0 50 00 FF	Off
		y0 50 01 FF	Flip H
		y0 50 02 FF	Flip V
		y0 50 03 FF	Flip HV
CAM_ Gamma Inq	8x 09 04 5B FF	y0 50 Op FF	p: Gamma setting
CAM_ VersionInq	8x 09 00 02 FF	y0 50 ab cd mn pq rs tu vw FF	ab cd : vender ID (0220) mn pq : model ID rs tu:ARM Version vw:reserve
VideoSystem	8x 09 06 23 FF	y0 50 Op FF	P: Video format 0:1080P60 1:1080P50 4:720P60 5:720P50 6:1080P30 7:1080P25 A:1080P59.94 C:720P59.94 D:1080P29.97 Ox19:4KP30 OX1A:4KP25

Command	Command pac- kage	Return Package	Remark
Pan- tiltMaxSpeedInq	8x 09 06 11 FF	y0 50 ww zz FF	ww: Pan Max Speed zz: Tilt Max Speed
Pan-tiltPosInq	8x 09 06 12 FF	y0 50 0w 0w 0w 0w Oz Oz Oz Oz FF	www: Pan Position zzzz: Tilt Position

8.1.4 Pelco-D Protocol command list

Function	Byte1	Byte2	Byte3	Byte4	Byte5	Byte6	Byte7
Up	0xFF	Address	0x00	0x08	Pan Speed	Tilt Speed	SUM
Down	0xFF	Address	0x00	0x10	Pan Speed	Tilt Speed	SUM
Left	0xFF	Address	0x00	0x04	Pan Speed	Tilt Speed	SUM
Right	0xFF	Address	0x00	0x02	Pan Speed	Tilt Speed	SUM
Upleft	0xFF	Address	0x00	0x0C	Pan Speed	Tilt Speed	SUM
Upright	0xFF	Address	0x00	0x0A	Pan Speed	Tilt Speed	SUM
Down left	0xFF	Address	0x00	0x14	Pan Speed	Tilt Speed	SUM
Down right	0xFF	Address	0x00	0x12	Pan Speed	Tilt Speed	SUM
Zoom In	0xFF	Address	0x00	0x20	0x00	0x00	SUM
Zoom out	0xFF	Address	0x00	0x40	0x00	0x00	SUM
Focus far	0xFF	Address	0x00	0x80	0x00	0x00	SUM
Focus near	0xFF	Address	0x01	0x00	0x00	0x00	SUM
Stop	0xFF	Address	0x00	0x80	0x00	0x00	SUM
Set preset	0xFF	Address	0x00	0x03	0x00	Preset ID	SUM
Clear preset	0xFF	Address	0x00	0x05	0x00	Preset ID	SUM
Call preset	0xFF	Address	0x00	0x07	0x00	Preset ID	SUM
Query Pan Position	0xFF	Address	0x00	0x51	0x00	0x00	SUM
Query Pan response	0xFF	Address	0x00	0x59	Value High Byte	Value Low Byte	SUM

Query Tilt Position	0xFF	Address	0x00	0x53	0x00	0x00	SUM
Query Tilt Position response	0xFF	Address	0x00	0x5B	Value High Byte	Value Low Byte	SUM
Query Zoom position	0xFF	Address	0x00	0x55	0x00	0x00	SUM
Query Zoom Position responde	0xFF	Address	0x00	0x5D	Value High Byte	Value Low Byte	SUM

8.1.5 Pelco-P Protocol command list

Function	Byte1	Byte2	Byte3	Byte4	Byte5	Byte6	Byte7	Byte8
Up	0xFF	Address	0x00	0x08	Pan Speed	Tilt Speed	0xAF	XOR
Down	0xFF	Address	0x00	0x10	Pan Speed	Tilt Speed	0xAF	XOR
Left	0xFF	Address	0x00	0x04	Pan Speed	Tilt Speed	0xAF	XOR
Right	0xFF	Address	0x00	0x02	Pan Speed	Tilt Speed	0xAF	XOR
Upleft	0xFF	Address	0x00	0x0C	Pan Speed	Tilt Speed	0xAF	XOR
Upright	0xFF	Address	0x00	0x0A	Pan Speed	Tilt Speed	0xAF	XOR
Down left	0xFF	Address	0x00	0x14	Pan Speed	Tilt Speed	0xAF	XOR
Down right	0xFF	Address	0x00	0x12	Pan Speed	Tilt Speed	0xAF	XOR
Zoom In	0xFF	Address	0x00	0x20	0x00	0x00	0xAF	XOR
Zoom out	0xFF	Address	0x00	0x40	0x00	0x00	0xAF	XOR
Focus far	0xFF	Address	0x00	0x80	0x00	0x00	0xAF	XOR
Focus near	0xFF	Address	0x01	0x00	0x00	0x00	0xAF	XOR
Stop	0xFF	Address	0x00	0x00	0x00	0x00	0xAF	XOR
Set preset	0xFF	Address	0x00	0x03	0x00	Preset ID	0xAF	XOR
Clear preset	0xFF	Address	0x00	0x05	0x00	Preset ID	0xAF	XOR
Call preset	0xFF	Address	0x00	0x07	0x00	Preset ID	0xAF	XOR
Query Pan Position	0xFF	Address	0x00	0x51	0x00	0x00	0xAF	XOR

Query Pan response	0xFF	Address	0x00	0x59	Value High Byte	Value Low Byte	SUM	XOR
Query Tilt Position	0xFF	Address	0x00	0x53	0x00	0x00	SUM	XOR
Query Tilt Position response	0xFF	Address	0x00	0x5B	Value High Byte	Value Low Byte	SUM	XOR
Query Zoom position	0xFF	Address	0x00	0x55	0x00	0x00	SUM	XOR
Query Zoom Position responde	0xFF	Address	0x00	0x5D	Value High Byte	Value Low Byte	SUM	XOR

9. Specifications

9.1 Camera Lens Parameter

Model	Cute 30X
Optical Zoom	30X
Image Sensor	1/2.8 inch high quality CMOS sensor
Effective Pixel	2.07M, 16: 9
Video Signal	HDMI/SDI: 1080P60, 1080P50, 1080i60, 1080i50, 1080P30, 1080P25, 720P60, 720P50 CVBS: 576i, 480i LAN Main Stream: 1920x1080, 1280x720, 640x480 Sub Stream: 1280x720, 640x480, 640x360, 320x240, 320x180
Optical Lens	30X f=4.3, 129 mm
Viewing Angle	2.34', N 65.1' W
Iris Value	F1.6, F4.7
Digital Zoom	X10
Minimum Illumination	0.5Lux(F1.8, AGC ON)
DNR	2D&3D
White Balance	Auto/Manual/One-push/Specified Color Temperature
Focus Mode	Auto/Manual/One-push
Exposure Mode	Auto, Manual, Shutter Priority, Iris Priority, Brightness Priority
Iris	F1.8 , F11, CLOSE

Shutter Speed	1/25, 1/10000
BLC	On/Off
Dynamic Range	Off, 1, 8
Video Adjustment	Brightness, Hue, Saturation, Contrast, Sharpness, Black and White Mode, Gamma Curve
SNR	>50dB

9.2 Interface Parameter

Back Panel	
Interface	HDMI, SDI, LAN, POE, NDI, CVBS, RS232-IN/OUT RS485, RS422, Audio-IN USB2.0(U disk storage)HDMI, DC12V Power Supply, Rotary Dip Switch, Power Switch
Video Output	HDMI, SDI, LAN, CVBS
Video Compression Format	LAN,H.264, H.265
Audio Input	Dual Channel 3.5mm linear input
Audio Output	HDMI, SDI, LAN
Audio Compression Format	AAC, MP3, G.711A
Network Port	100M Ethernet port, support POE power supply, support audio and video output
Network Protocols	RTSP, RTMP, ONVIF, GB/T28181, VISCA OVER IP, IP VISCA, RTMPS, SRT and NDI Support remote upgrade, remote restart, remote reset
Control	RS232-IN, RS232-OUT, RS422 compatible with RS485
Serial Port Communication Protocols	VISCA/Pelco-D/Pelco-P Baud rate: 115200/38400/9600/4800/2400
USB Communication Protocols	UVC, Video Communication Protocols), UAC, Audio Communication Protocols
Power Port	HEC3800 Power socket(DC12V)
Power Adapter	Input: AC110V-AC220V, Output: DC12V/2.5A
Input Voltage	DC12V±10%
Input Currency	<1A
Power Consumption	<12W

PTZ Parameter	
Pan Move	-170° - +170°
Tilt Move	-30° - +90°
Pan Speed	1.4°/s - 40°/s
Tilt Speed	2.9°/s - 30°/s
Preset Speed	Pan: 40°/s, Tilt: 30°/s
Preset Quantity	Up to 255 preset (10 via remote control)

Other Parameter	
Storage Temperature	-10°C - 60°C
Storage Humidity	20% - 95%
Working Temperature	-10°C - 50°C
Working Humidity	20% - 80%
Dimension	143(L)mm*176mm(W)*169mm(H)
Weight	1.3kg
Environment	Indoors

10. Mounting options

10.1 Wall mounting

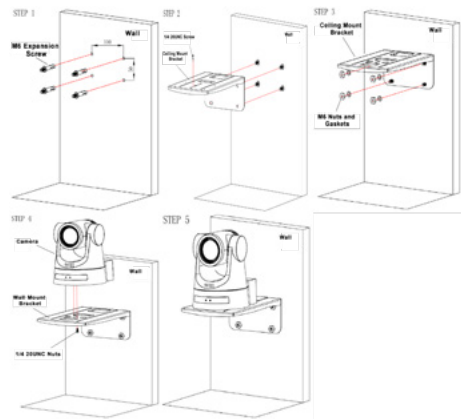

10.2 Ceiling Mount

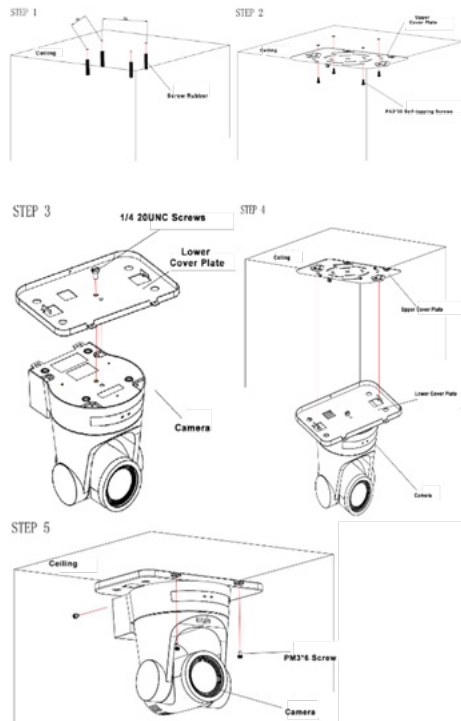

11. Troubleshooting & tips

11.1 Camera maintenance

If you are not going to use the camera for a long time, turn it off. Use a soft cloth or tissue to clean the camera body. Use a soft, dry, lint-free cloth to clean the lens. If the camera is very dirty, clean it with a diluted neutral detergent. Do not use any type of solvent or strong detergent, as this could damage the surface.

11.2 Not recommended uses

- Do not photograph extremely bright objects for a long period of time, such as sunlight, ultra-bright light sources, etc.
- Do not use the camera in unstable lighting conditions, as the image may flicker.
- Do not use the camera near strong electromagnetic radiation, such as TV or radio transmitters, etc.

11.3 Problem solving

No image:

- Check if the power cord is connected, the voltage is correct, and the power indicator is on.
- Check if the camera can "self-test" after power on (the camera will briefly pan, tilt and return to the home position, or if preset 0, the camera will return to the preset 0 position)
- Check that the HDMI cable is connected correctly.

Abnormal image display:

- Check the setting of the rotary dial on the back of the camera. Be sure to use a resolution and refresh rate supported by the software.

Image shakes or vibrates:

- Check if the camera is mounted firmly or on a horizontal and level surface.
- Check whether the supporting furniture vibrates. Roof mounts tend to be more affected by building vibrations than wall mounts. Any external vibration that is affecting the camera will be more apparent when it is zoomed in.

Precautions

This product can only be used under the specified conditions to avoid any damage to the camera:

1. Do not expose the product to rain or moisture.
2. To avoid the risk of electric shock, do not open the case. Installation and maintenance should only be carried out by qualified technicians.
3. Do not use the product at temperatures, humidity or power sources higher than specified.

Setting up

Do not violently rotate the camera head, otherwise it may cause mechanical failure. This product should be placed on a stable desktop or other horizontal surface. Do not install the product obliquely, otherwise it may display a tilted image. Make sure there are no obstacles in the bracket's turning radius. Please do not power on before fully installed.

12. Interface

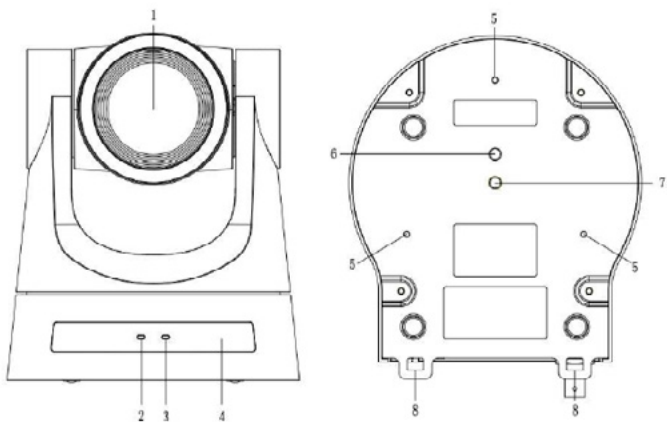

1. Camera Lens
2. Power Light
3. Status Light
4. Infrared Receiver
5. Tripod Screw Hole
6. Tripod Screw Hole
7. Screw Hole for Tripod
8. Safe Lock
9. 3G-SDI Output Interface
10. HDMI Output Interface
11. USB2.0 Interface (USB flash drive port only)
12. LAN Port (NDI)
13. DC12V Input Power Supply Socket
14. Power Switch
15. Rotary DIP Switch
16. RS232 Control Interface (input)
17. RS232 Control Interface (output)
18. RS485 Input (left +, right-)
19. RS422 Input
20. Audio Input Interface (Line-in)
21. CVBS Output Interface

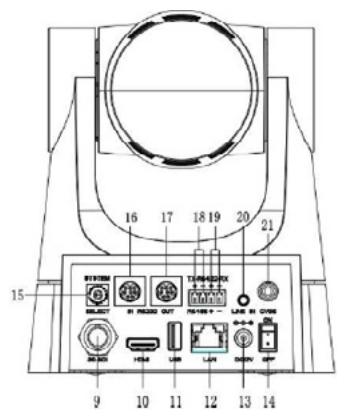



laiatech.com